



[Browse Product Range >](#)

Westfield Fasteners Product Specification:

Cup Washers, Stamped Type (NF E 27-619)

This product guide contains the specification for Cup Washers Stamped Type, a series of standard parts available from Westfield Fasteners. The basis of this specification is the internationally recognised French standard NF E 27-619.

Product Description

Cup Stamped Washers are also known as stamped metal finishing washers, seating washers and dished cup washers. For use with a countersunk bolt or wood screw, they give an attractive look to an exposed screw head. Often used in the furniture industry and to grip fabric and other light materials securely surrounding the screw head.

Scope of the DIN Standard

NF E 27-619 is a French standard for countersunk cup washers, both the solid machined type and the pressed type we are concerned with here. Figure 1 and table 1 below show the dimensions and tolerances for sizes from M3 up to M14.

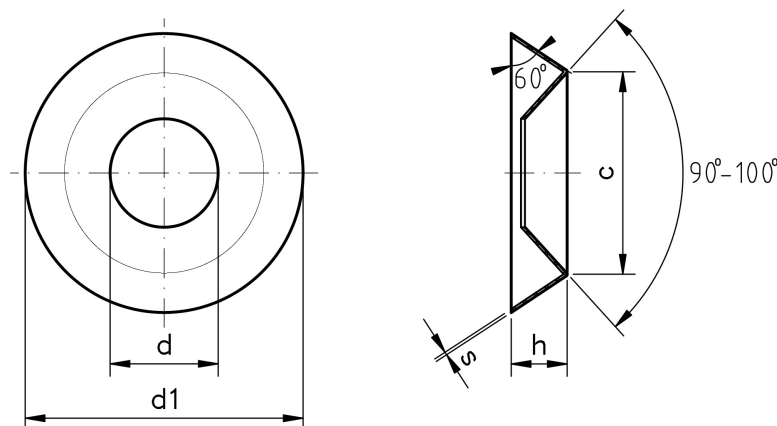

Figure 1: Countersunk Cup Washer, Stamped Type

Table 1: Dimensions & Tolerances according to NF E 27-619

Nominal Diameter	Hole Diameter, d	Overall Diameter, d1	Csk Diameter, c	Height, h	Thickness, s
	Tol +0.3, +0.0	Tol +0.3, +0.0	Tol +0.3, +0.0	Tol +/-0.2	
3	3.5	9	6.5	2	0.25
4	4.5	11	8	2.5	0.25
5	5.5	14	10	3	0.25
6	7	16	12	3.5	0.30
8	9	22	16	4.5	0.30
10	11	28	20	5.5	0.30
12	14	32	24	6.5	0.40
14	16	36	28	7.5	0.40

For further details, please refer to the NF standard document for this item.