

Westfield Fasteners Product Specification:

DIN 603 & DIN 555 - Coach Bolts (Cup Head Square Neck Bolts) with Nuts

This product guide contains the specification for metric threaded coach bolts / carriage bolts when supplied with matching nut as available from Westfield Fasteners. The basis of this specification is the DIN standards DIN 603 and DIN 555.

Product Description

Generally used in timber to timber and timber to metal construction, these bolts incorporate a square neck to grip the hole in the timber when fitting, and therefore negates the need for any drive recess to be included on top of the head. Supplied to DIN 603 and DIN 555. Usually manufactured with a full thread, though often some stock may include a partially threaded shank, particularly on longer lengths. Comes complete with hexagon nut to fit.

Scope of the ISO standard.

DIN 603 specifies the tolerances and the permissible variation in form of carriage bolts / coach bolts / cup head bolts, and covers metric thread diameters from M5 up to and including M20. Similarly, DIN 555 does so for the nuts. Mechanical properties for these items are defined in ISO 898 and ISO 3506.

Table 1 below defines the overall dimensions and tolerances of this screw type, whilst table 2 defines the tolerances on the shank length. Table 3 defines the detail of the accompanying nut.

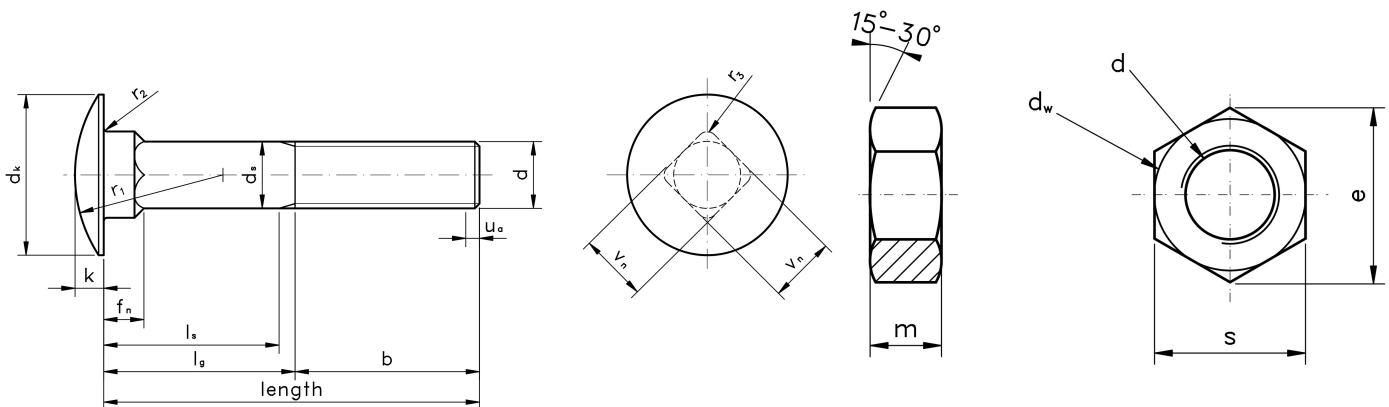

Countersunk at start of thread permissible at either side.

Figure 1: Socket Head Countersunk Screw

Notes to figure 1:

- There may be up to 2 incomplete threads at the end of the bolt (a).

Variations from DIN 603 & DIN 555

In our experience, we find that these coach bolts are most often supplied with nuts conforming to DIN 934 instead of DIN 555. Please see the data sheet for DIN 934 for these specifications, which have minor variations in the dimensions compared to DIN 555.

With regard to thread lengths, the manufacturers often stray away from the standard when deciding how much thread to apply to the shank on these bolts. Therefore, the thread lengths quoted in table 2 should be considered a minimum, and should be taken as a guide only.

Table 1: Dimensions & Tolerances according to DIN 603 (ScrewBolt)

Thread, d		M5	M6	M8	M10	M12	M16	M20
thread pitch (standard metric coarse)		0.8	1	1.25	1.5	1.75	2	2.5
thread length	b min. (shank length ≤ 125mm)	16	18	22	26	30	38	46
	b min. (shank length > 125mm ≤ 200mm)	22	24	28	32	36	44	52
	b min. (shank length > 200mm)	-	-	41	45	49	57	65
head diameter	d _k max.	13.55	16.55	20.65	24.65	30.65	38.80	46.80
	d _k min.	12.45	15.45	19.35	23.35	29.35	37.20	45.20
shank diameter	d _s max.	5	6	8	10	12	16	20
	d _s min.	4.52	5.52	7.42	9.42	11.30	15.30	19.16
neck height	f _n max.	4.10	4.60	5.60	6.60	8.75	12.90	15.90
	f _n min.	2.90	3.40	4.40	5.40	7.25	11.10	14.10
head height	k max.	3.30	3.88	4.88	5.38	6.95	8.95	11.05
	k min.	2.70	3.12	4.12	4.65	6.05	8.05	9.95
head radius	r ₁ ≈ (approx.)	10.7	12.6	16	19.2	24.1	29.3	33.9
neck radius	r ₂ max.	0.5	0.5	0.5	0.5	1.0	1.0	1.0
square neck radius	r ₃ max.	0.75	0.90	1.20	1.50	1.80	2.40	3.0*
neck thickness	v _n max.	5.48	6.48	8.58	10.58	12.70	16.70	20.84
	v _n min.	4.52	5.52	7.42	9.42	11.30	15.30	19.16

*The dimensional table from DIN Standard 603:2017-05 states this dimension to be 30mm not 3.0mm, however we believe this is a mistake.

Table 2: Shank Length Tolerance according to DIN 603

total shank length			M5		M6		M8		M10		M12		M16		M20	
			unthreaded shank length (l_s) and distance from head to first full form thread profile(l_g)													
Nom. size	min	max	l_s min	l_g max	l_s min	l_g max	l_s min	l_g max	l_s min	l_g max	l_s min	l_g max	l_s min	l_g max	l_s min	l_g max
16	15.10	16.90	-	8	-	10	/	/	/	/	/	/	/	/	/	/
20	18.95	21.05	-	8	-	10	-	12	-	14	/	/	/	/	/	/
25	23.95	26.05	-	8	-	10	-	12	-	14	/	/	/	/	/	/
30	28.95	31.05	-	18	-	10	-	12	-	14	-	18	/	/	/	/
35	33.75	36.25	15	19	12	17	-	12	-	14	-	18	/	/	/	/
40	38.75	41.25	20	24	17	22	11.75	18	-	14	-	18	/	/	/	/
45	43.75	46.25	25	29	22	27	16.75	23	11.5	19	-	18	/	/	/	/
50	48.75	51.25	30	34	27	32	21.75	28	16.5	24	-	18	/	/	/	/
55	53.50	56.50	35	39	32	37	26.75	33	21.5	29	16.25	25	-	23	/	/
60	58.50	61.50	40	44	37	42	31.75	38	26.5	34	21.25	30	-	23	/	/
65	63.50	66.50	45	49	42	47	36.75	43	31.5	39	26.75	35	17	27	/	/
70	68.50	71.50	50	54	47	52	41.75	48	36.5	44	31.25	40	22	32	-	28.5
80	78.50	81.50	60	64	57	62	51.75	58	46.5	54	41.25	50	32	42	21.5	34
90	88.25	91.75	-	-	67	72	61.75	68	56.5	64	51.25	60	42	52	31.5	44
100	98.25	101.75	-	-	77	82	71.75	78	66.5	74	61.25	70	52	62	41.5	54
110	108.25	111.75	-	-	87	92	81.75	88	76.5	84	71.25	80	62	72	51.5	64
120	118.25	121.75	-	-	97	102	91.75	98	86.5	94	81.25	90	72	82	61.5	74
130	128.00	132.00	-	-	101	106	95.75	102	90.5	98	85.25	94	76	86	65.5	78
140	138.00	142.00	-	-	111	116	105.75	112	100.5	108	95.25	104	86	96	75.5	88
150	148.00	152.00	-	-	121	126	115.75	122	110.5	118	105.25	114	96	106	85.5	98
160	156.00	164.00	-	-	-	-	-	-	120.5	128	115.25	124	106	116	95.5	108
180	176.00	184.00	-	-	-	-	-	-	140.5	148	135.25	144	126	136	115.5	128
200	195.40	204.60	-	-	-	-	-	-	160.5	168	155.25	164	146	156	135.5	148

Table 3: Dimensional Tolerances according to DIN 555 (Nut)

Thread, d		M5	M6	M8	M10	M12	M16	M20	M22	M24	M27	M30	M33	M36	M39	M42	M45	M48	M52	M56	M60	M64	M72X6	M80X6	M90X6	M100X6
	p	0.8	1	1.25	1.5	1.75	2	2.5	2.5	3	3	3.5	3.5	4	4	4.5	4.5	5	5	5.5	6	6	-	-	-	-
d _w e	min	6.7	8.7	11.5	15.5	17.2	22	27.7	29.5	33.2	38	42.7	46.5	51.1	55.9	59.9	64.7	69.4	74.2	78.7	83.4	88.2	97.7	107.2	121.1	135.4
	min	8.63	10.89	14.2	18.72	20.88	26.17	32.95	35.05	39.55	45.20	50.85	55.37	60.79	66.44	71.30	76.95	82.6	88.25	93.56	99.23	104.86	116.16	127.46	144.08	161.02
m	nom	4	5	6.5	8	10	13	16	18	19	22	24	26	29	31	34	36	38	42	45	48	51	58	64	72	80
	max	4.6	5.6	7.25	8.75	10.75	13.9	16.9	18.9	20.05	23.05	25.05	27.05	30.05	32.25	35.25	37.25	39.25	43.25	46.25	49.25	52.50	59.50	65.50	73.50	81.50
	min	3.4	4.4	5.75	7.25	9.25	12.1	15.1	17.1	17.95	20.95	22.95	24.95	27.95	29.75	32.75	34.75	36.75	40.75	43.75	46.75	49.50	56.50	62.50	70.50	78.50
s	max=nom	8	10	13	17	19	24	30	32	36	41	46	50	55	60	65	70	75	80	85	90	95	105	115	130	145
	min	7.64	9.64	12.57	16.57	18.48	23.16	29.16	31	35	40	45	49	53.8	58.8	63.1	68.1	73.1	78.1	82.8	87.8	92.8	102.8	112.8	127.5	142.5

For further details, please refer to the ISO/DIN standard document for this item.