



[Browse Product Range >](#)

Westfield Fasteners Product Specification:

DIN 963 - Slotted Countersunk Head Screws

This product guide contains the specification for metric threaded slotted countersunk screws as available from Westfield Fasteners. The basis of this specification is the DIN standard DIN 963.

Product Description

A slot drive, countersunk headed screw, typically used in conjunction with a countersunk hole which provides a flush, snag free fit.

Scope of the DIN 963 standard.

The DIN 963 standard specifies the tolerances and variation in form of slotted countersunk head machine screws, and covers metric thread diameters for sizes M1 up to and including M20. Table 1 below defines the overall dimensions and tolerances of this screw type, and should be used in conjunction with the diagram in figure 1. Table 2 defines the tolerance on the overall length. It should be noted that all lengths stated for countersunk screws are for the overall length, including the head. This is different from other types of screw that have heads designed to sit above the surface of the workpiece. In this case lengths quoted are for the shank length under, but not including the head. These are generally fully threaded. The ISO standard does include details for the part threaded version, which we have not covered here.

DIN 963 covers steel classes 4.8, 5.8 and high tensile 8.8, together with A2 and A4 stainless steel, and copper and zinc alloy (brass).

Although the DIN 963 standard has now been superseded by ISO 2009, off the shelf parts are generally still manufactured to the older specification. The ISO standard specifies some revised dimensions and tolerances.

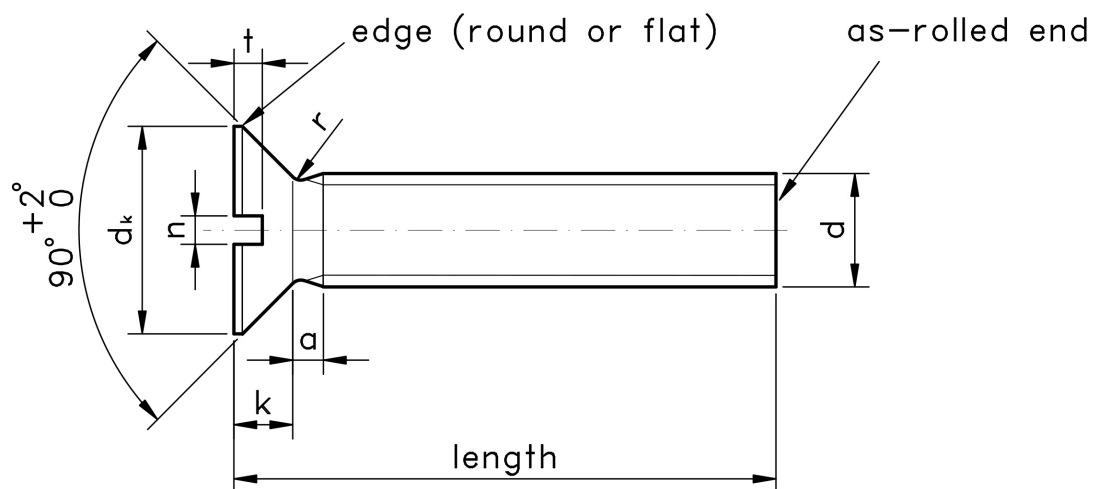

Figure 1: Slotted Countersunk Head Machine Screw

Variations from DIN 963

The DIN standard allows for a partially threaded shank, but off the shelf slotted countersunk head machine screws are seldom seen with this variation.

Although DIN 963 covers many thread diameters, this Westfield Fasteners specification only covers those diameters that are generally available off-the-shelf.

Please note that due to manufacturing limitations, all nylon variants of these items are only "similar to" and not "in absolute accordance with" this standard.

Table 1: Dimensions & Tolerances according to DIN 963

Thread, d		M1.6	M2	M2.5	M3	M3.5	M4	M5	M6	M8	M10
thread pitch (standard metric coarse)	P	0.35	0.4	0.45	0.5	0.6	0.7	0.8	1	1.25	1.5
thread runout	a max.	0.7	0.8	0.9	1	1.2	1.4	1.6	2	2.5	3
head diameter	d _k max. = nominal size	3.0	3.8	4.7	5.6	6.5	7.5	9.2	11.0	14.5	18.0
	dk min.	2.86	3.5	4.4	5.3	6.14	7.14	8.84	10.57	14.07	17.57
head height	k max.	0.96	1.2	1.5	1.65	1.93	2.2	2.5	3.0	4.0	5.0
slot width	n nominal	0.4	0.5	0.6	0.8	0.8	1.0	1.2	1.6	2	2.5
	n min.	0.46	0.56	0.66	0.86	0.86	1.06	1.26	1.66	2.06	2.56
	n max.	0.60	0.70	0.80	1.0	1.0	1.2	1.51	1.91	2.31	2.81
neck radius	r max.	0.16	0.2	0.25	0.3	0.35	0.4	0.5	0.6	0.8	1.0
slot depth	t min.	0.32	0.4	0.5	0.6	0.7	0.8	1.0	1.2	1.6	2.0
	t max.	0.45	0.6	0.7	0.85	1.0	1.1	1.3	1.6	2.1	2.6

Table 2: Shank Length Tolerance according to DIN 963

shank length (mm)	+/- (mm)
2-3	0.20
4-6	0.25
8-10	0.30
12-18	0.35
20-30	0.40
35-50	0.50
55-80	1.00

For further details, please refer to the relevant ISO/DIN standard document for this item.