



Westfield Fasteners Product Specification:

DIN 912 - Hexagon Socket Head Cap Screws

This product guide contains the specification for metric threaded socket head cap screws, a series of standard parts available from Westfield Fasteners. The basis of this specification is the DIN standard DIN 912.

Product Description

Hexagon socket head cap screws, also known as allen screws or allen bolts, or simply cap screws, are a modern machine threaded fastener. They are an alternative design to the standard hexagon headed bolt or set screw seen everywhere today. A hex key of the right size (otherwise known as an Allen key) is required to fit these fasteners. An alternative standard ISO 4762 exists in parallel with DIN 912 and includes some minor differences, but to all intents and purposes the parts involved are interchangeable.

Scope of the DIN standard.

The DIN 912 standard specifies the tolerances and the variation in form of socket head cap screws, for sizes M1.4 up to and including M100. Mechanical properties for these items are defined in ISO 898, ISO 3506 and DIN 267. Table 1 below defines the overall dimensional tolerances of this screw type. Table 2 defines the tolerances on the shank length.

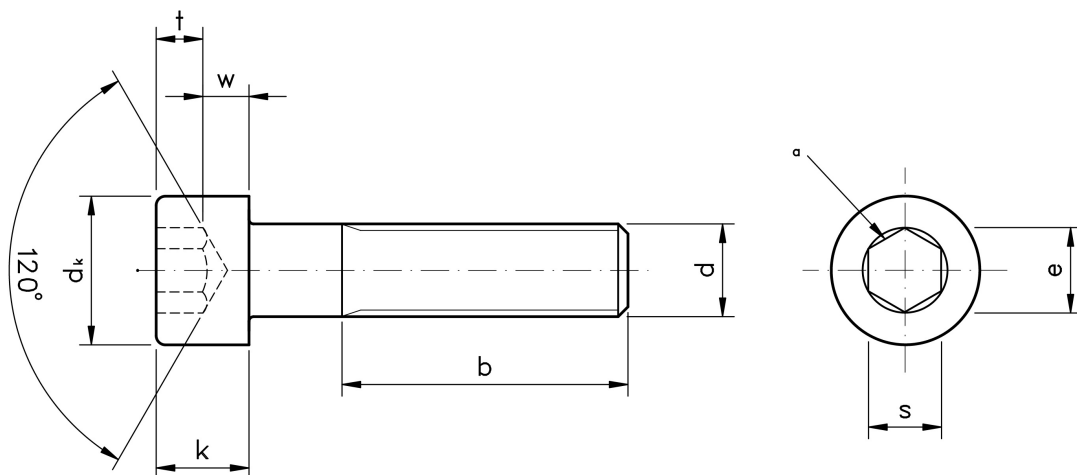

Figure 1: Hexagon Socket Head Cap Screws

Notes to figure 1:

- Slight rounding or countersink at the mouth of the socket (a) may be present.
- The threaded end of the bolt can be chamfered or rounded.
- There may be up to 2 incomplete threads at the end of the bolt.
- The top edge of the cylindrical head can be rounded or chamfered. The bottom edge can also be rounded or chamfered, but in both cases must be free from burrs.

Variations from DIN 912

Manufacturer and/or material markings may be present on the top face of the head.

DIN 912 covers A2-70 and A4-70 stainless steel, and hi-tensile steel 8.8, 10.9 and 12.9. It does not specifically mention duplex or A4-80 stainless steel, but the dimensions will follow this standard.

Due to manufacturing limitations, nylon versions of socket head cap screws are only similar to and not in full compliance with this specification.

The specification here includes dimensional data from M1.6 to M64 in line with ISO 4762, rather than the sizes covered in DIN 912.

Table 1: Dimensional Tolerances according to DIN 912 / ISO 4762

Thread, d		M1.6	M2	M2.5	M3	M4	M5	M6	M8	M10	M12	M14	M16	M20	M24	M30	M36	M42	M48	M56	M64
p		0.35	0.4	0.45	0.5	0.7	0.8	1	1.25	1.5	1.75	2	2	2.5	3	3.5	4	4.5	5	5.5	6
b	ref.	15	16	17	18	20	22	24	28	32	36	40	44	52	60	72	84	96	108	124	140
d _k	max	3.00	3.80	4.50	5.50	7.00	8.50	10.00	13.00	16.00	18.00	21.00	24.00	30.00	36.00	45.00	54.00	63.00	72.00	84.00	96.00
	max	3.14	3.98	4.68	5.68	7.22	8.72	10.22	13.27	16.27	18.27	21.33	24.00	30.33	36.39	45.39	54.46	63.46	72.46	84.54	96.54
	min	2.86	3.62	4.32	5.32	6.78	8.28	9.78	13.73	15.73	17.73	20.67	23.67	29.67	35.61	44.61	53.54	62.54	71.54	83.46	95.46
d _a	max	2	2.6	3.1	3.6	4.7	5.7	6.8	9.2	11.2	13.7	15.7	17.7	22.4	26.4	33.4	39.4	45.6	52.6	63.0	71.0
d _s	max	1.60	2.00	2.50	3.00	4.00	5.00	6.00	8.00	10.00	12.00	14.00	16.00	20.00	24.00	30.00	36.00	42.00	48.00	56.00	64.00
	min	1.46	1.86	2.36	2.86	3.82	4.82	5.82	7.78	9.78	11.73	13.73	15.73	19.67	23.67	29.67	35.67	41.61	47.61	55.54	63.54
e	min	1.733	1.733	2.303	2.873	3.443	4.583	5.723	6.863	9.149	11.429	13.716	15.996	19.437	21.734	25.154	30.854	36.571	41.131	46.831	52.531
l _f	max	0.34	0.51	0.51	0.51	0.6	0.6	0.68	1.02	1.02	1.45	1.45	1.45	2.04	2.04	2.89	2.89	3.06	3.91	5.95	5.95
k	max	1.60	2.00	2.50	3.00	4.00	5.00	6.00	8.00	10.00	12.00	14.00	16.00	20.00	24.00	30.00	36.00	42.00	48.00	56.00	64.00
	min	1.64	1.86	2.36	2.86	3.82	4.82	5.7	7.64	9.64	11.57	13.57	15.57	19.48	23.48	29.48	35.38	41.38	47.38	55.26	63.26
r	min	0.1	0.1	0.1	0.1	0.2	0.2	0.25	0.4	0.4	0.6	0.6	0.6	0.8	0.8	1	1	1.2	1.6	2	2
s	nom	1.5	1.5	2	2.5	3	4	5	6	8	10	12	14	17	19	22	27	32	36	41	46
	max	1.58	1.58	2.08	2.58	3.08	4.095	5.14	6.14	8.175	10.175	12.212	14.212	17.230	19.275	22.275	27.275	32.330	36.330	41.33	46.33
	min	1.52	1.52	2.02	2.52	3.02	4.020	5.02	6.02	8.025	10.025	12.032	14.032	17.050	19.065	22.065	27.065	32.080	36.080	41.080	46.080
t	min	0.7	1	1.1	1.3	2	2.5	3	4	5	6	7	8	10	12	15.5	19	24	28	34	38
v	max	0.16	0.2	0.25	0.3	0.4	0.5	0.6	0.8	1	1.2	1.4	1.6	2	2.4	3	3.6	4.2	4.8	5.6	6.4
d _w	min	2.72	3.48	4.18	5.07	6.53	8.03	9.38	12.33	15.33	17.23	20.17	23.17	28.87	34.81	43.61	52.54	61.34	70.34	82.26	94.26
w	min	0.55	0.55	0.85	1.15	1.4	1.9	2.3	3.3	4	4.8	5.8	6.8	8.6	10.4	13.1	15.3	16.3	17.5	19	22

Table 2: Shank Length Tolerance according to DIN 912

shank length (mm)	+/- (mm)
2.5-3	0.2
4-6	0.24
8-10	0.29
12-16	0.35
20-30	0.42
35-50	0.5
55-80	0.6
90-120	0.7
130-180	0.8
200-240	0.9
260-300	1.05

For further details, please refer to the ISO/DIN standard document for this item.