



[Browse Product Range >](#)

## Westfield Fasteners Product Specification:

### DIN 960 - Metric Fine Threaded Hex Head Bolts with Partial Thread

This product guide contains the specification for metric fine pitch threaded hex head bolts with a partial threaded shank, a series of standard parts available from Westfield Fasteners. The basis of this specification is the internationally recognised DIN standard DIN 960.

#### Product Description

The most common type of fastener, a hex head bolt is designed to be tightened with a standard spanner or ratchet and socket. Popularly used in all assemblies, a standard hex bolt is a staple across the world. Manufactured to DIN 931 or ISO 4014, and therefore includes an unthreaded section of the shaft or shank. A hex drive permits a greater torque load to be applied to the joint over most other drive types. The newer standard ISO 4014 specifies differences in head dimensions for M10, M12, M14 and M22 thread diameters from DIN 931.

#### Scope of the DIN standard.

DIN 931 has specific provision for mild steel, 8.8 and 10.9 hi-tensile steel, stainless steel and non ferrous metals.

Although the DIN 931 standard has now been withdrawn and superceded by ISO 4014, off the shelf parts are generally still manufactured to the older specification.

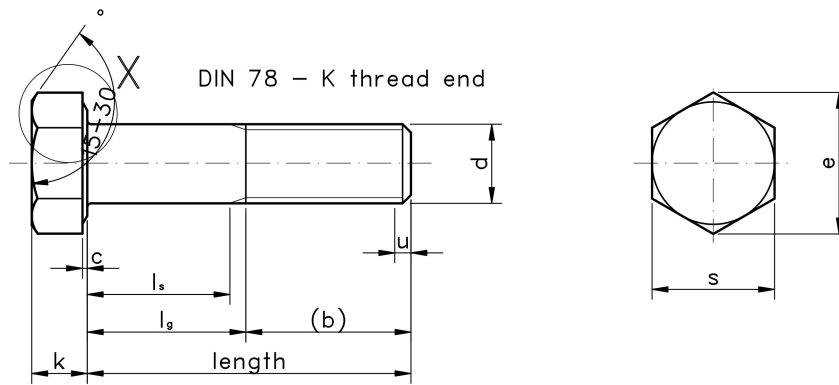

$u = \text{maximum of } 2 P \text{ (incomplete threads)}$

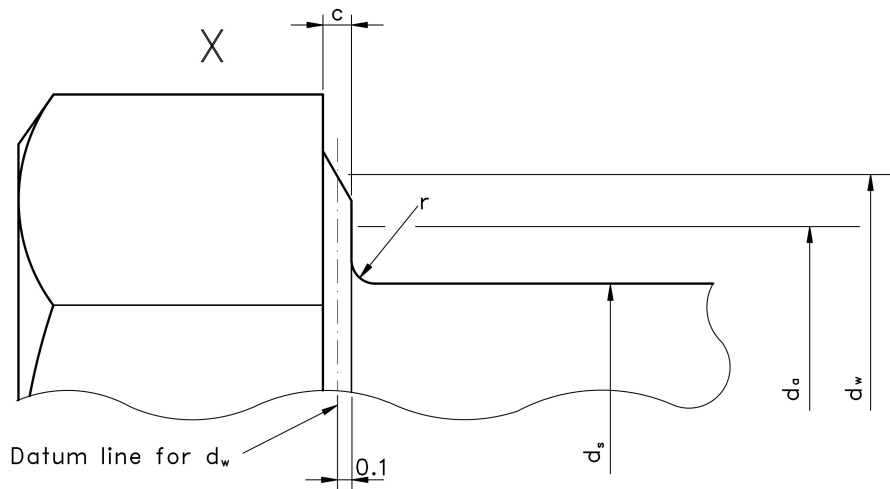

**Notes to figure 1:**

- The threaded end of the bolt (b) can be chamfered or sheared as rolled.
- There may be up to 2 incomplete threads at the end of the bolt (c).
- d - The datum reference for  $d_w$  is in the centre of the depth of the step beneath the head.

**Variations from DIN 931**

ISO 4014, which replaces DIN 931, specifies revised dimensions and tolerances for hex head set screws, most particularly new head dimensions for M10, M12, M14 and M22. Parts conforming specifically to ISO 4014 can be sourced, but are subject to availability.

ISO 4017 is an equivalent standard, covering hex head bolts with a fully threaded shank.

Table 1: Dimensions & Tolerances according to DIN 931 (Preferred Threads)

Thread, d			M1.6	M2	M2.5	M3	M4	M5	M6	M8	M10	M12	M16	M20	M24	M30	M36	M42	M48	M56	M64	
p			0.35	0.4	0.45	0.5	0.7	0.8	1	1.25	1.5	1.75	2	2.5	3	3.5	4	4.5	5	5.5	6	
b ref	for shank length ≤ 125		9	10	11	12	14	16	18	22	26	30	38	46	54	66	78	90	102	-	-	
	for shank length > 125 and ≤ 200		-	-	-	-	-	22	24	28	32	36	44	52	60	72	84	96	108	124	140	
	for shank length > 200		-	-	-	-	-	-	-	-	45	49	57	65	73	85	97	109	121	137	153	
c		max	0.25	0.25	0.25	0.40	0.40	0.50	0.50	0.60	0.60	0.60	0.80	0.80	0.8	0.8	0.8	1	1	1	1	
		min	0.10	0.10	0.10	0.15	0.15	0.15	0.15	0.15	0.15	0.15	0.15	0.2	0.2	0.2	0.2	0.2	0.3	0.3	-	-
d <sub>a</sub>		max	2.0	2.6	3.1	3.6	4.7	5.7	6.8	9.2	11.2	13.7	17.7	22.4	26.4	33.4	39.4	45.6	52.6	63	71	
d <sub>s</sub>	-	nom = max	1.6	2	2	3	4	5	6	8	10	12	16	20	24	30	36	42	48	56	64	
	Product grade	A	min	1.46	1.86	2.36	2.86	3.82	4.82	5.82	7.78	9.78	11.73	15.73	19.67	23.67	-	-	-	-	-	-
		B		-	-	-	-	-	-	-	-	-	-	15.57	19.48	23.48	29.48	35.38	41.61	47.38	55.26	63.26
d <sub>w</sub>	Product grade	A	min	2.4	3.2	4.1	4.6	5.9	6.9	8.9	11.63	14.63	16.63	22.49	28.19	33.6	-	-	-	-	-	-
		B		-	-	-	-	-	-	-	-	-	-	22.00	27.70	33.2	42.7	51.1	60.6	69.4	78.7	88.2
e	Product grade	A	min	3.41	4.32	5.45	6.01	7.66	8.79	11.05	14.38	118.9	21.1	26.75	33.53	39.98	-	-	-	-	-	-
		B		-	-	-	-	-	-	-	-	-	-	26.17	32.95	39.55	50.85	60.79	71.30	82.60	93.56	104.86
k	nom		1.1	1.4	1.7	2	2.8	3.5	4	5.3	6.4	7.5	10	12.5	15	18.7	22.5	26	30	35	40	
	Product grade	A	max	1.22	1.52	1.82	2.12	2.92	3.65	4.15	5.45	6.58	7.68	10.18	12.72	15.22	-	-	-	-	-	-
			min	0.98	1.28	1.58	1.88	2.68	3.35	3.85	5.15	6.22	7.32	9.82	12.28	14.78	-	-	-	-	-	-
	Product grade	B	max	-	-	-	-	-	-	-	-	-	-	10.29	12.85	15.35	19.12	22.92	26.42	30.42	35.5	40.5
min			-	-	-	-	-	-	-	-	-	-	-	9.71	12.15	14.65	18.28	22.08	25.58	29.58	34.5	39.5
k <sub>w</sub>	-	-	min	0.7	0.9	1.1	1.3	1.9	2.28	2.63	3.54	4.28	5.05	6.8	8.5	10.3	12.8	15.5	17.9	20.9	24.2	27.6
r	min		0.1	0.1	0.1	0.1	0.2	0.2	0.25	0.4	0.4	0.6	0.6	0.8	0.8	1	1	1.2	1.6	2	2	
s	-	nom = max	3.2	4	5	5.5	7	8	10	13	17	19	24	30	36	46	55	65	75	85	95	
	Product grade	A	min	3.02	3.82	4.82	5.32	6.78	7.78	9.78	12.73	16.73	18.67	23.67	29.67	35.38	-	-	-	-	-	-
		B		-	-	-	-	-	-	-	-	-	-	23.16	29.16	35	45	53.8	63.1	73.1	82.8	92.8

**Table 2: Dimensions & Tolerances according to DIN 931 (Non-preferred Threads)**

Thread, d			M3.5	M7	M14	M18	M22	M27	M33	M39	M45	M52	M60
p			0.6	1	2	2.5	2.5	3	3.5	4	4.5	5	5.5
b ref	for shank length ≤ 125		13	20	34	42	50	60	72	84	96	-	-
	for shank length > 125 and ≤ 200		-	26	40	48	56	66	78	90	102	116	132
	for shank length > 200		-	-	53	61	69	79	91	103	115	129	145
c			max	0.4	0.5	0.6	0.8	0.8	0.8	0.8	1	1	1
			min	0.15	0.15	0.15	0.2	0.2	0.2	0.2	0.3	0.3	0.3
d <sub>a</sub>			max	4.1	7.8	15.7	20.2	24.4	30.4	36.4	42.4	48.6	56.6
d <sub>s</sub>	-		nom = max	3.5	7	14	18	22	27	33	39	45	52
	Product grade	A	min	3.32	6.78	13.73	17.73	21.67	-	-	-	-	-
		B		-	-	-	17.57	21.48	26.48	32.38	38.38	44.38	51.26
d <sub>w</sub>	Product grade	A	min	5.1	9.6	20.5	25.3	30	-	-	-	-	-
		B		-	-	-	24.8	29.5	38	46.6	55.9	64.7	74.2
e	Product grade	A	min	6.58	12.12	24.49	30.14	35.72	-	-	-	-	-
		B		-	-	-	29.56	35.03	45.2	55.37	66.44	76.95	88.25
k	nom			2.4	4.8	8.8	11.5	14	17	21	25	28	33
	Product grade	A	max	2.52	4.95	8.98	11.72	14.22	-	-	-	-	-
			min	2.28	4.65	8.62	11.28	13.78	-	-	-	-	-
	Product grade	B	max	-	-	-	11.85	14.35	17.35	21.42	25.42	28.42	33.5
min			-	-	-	11.15	13.65	16.65	20.58	24.58	27.58	32.5	37.50
k <sub>w</sub>	-		min	1.6	3.19	5.96	7.8	9.6	11.7	14.4	17.2	19.3	22.8
r	min			0.1	0.25	0.6	0.6	0.8	1	1	1	1.2	1.6
s	-		nom = max	6	11	22	27	32	41	50	60	70	80
	Product grade	A	min	5.82	10.73	21.67	26.67	31.61	-	-	-	-	-
		B		-	-	-	26.16	31	40	49	58.8	68.1	78.1

**Table 3: Shank Length Tolerance according to DIN 931**

Thread mm	Product Grade +/- (mm)	
	A	B
12-18	0.35	-
20-30	0.42	-
35-50	0.5	-
55-80	0.6	-
85-120	0.7	1.75
130-180	0.8	2
190-200	0.92	2.3
200-240	-	2.3
260-300	-	2.6
320-400	-	2.85
420-500	-	3.15

For further details, please refer to the ISO/DIN standard document for this item.