



## Westfield Fasteners Product Specification:

# DIN 7500 - Torx Countersunk Thread Rolling Screws for ISO Metric Threads

This product guide contains the specification for metric threaded torx countersunk thread rolling screws, a series of standard parts available from Westfield Fasteners. The basis of this specification is the DIN standard DIN 7500.

## Product Description

Thread rolling screws are designed to tap their own threads into pre-drilled holes in light metals and steel. The end of these screws have a triangular tip and the threads decrease in height towards the tip. This design allows the thread rolling screw to form a thread by forcing the softer material outwards, so no need to tap the hole.

As these tapping screws 'cold form' the thread by displacing it, they don't cause chips and swarf to occur. Another benefit of this method of thread forming is that it increases resistance to vibration and loosening of the fastening,

They are able to create threads into ductile metals to a depth that is twice their diameter. Drilling the correct pilot hole diameter for the screw to form the thread is crucial.

## Scope of the DIN standard.

DIN 7500 specifies the requirements for case hardened and tempered metric thread forming screws, with various forms of head geometry. The screws in this standard are designed to form internal ISO metric threads, with a nominal diameter from 2 mm to 12 mm. Part one of this standard outlines the technical specifications for the screws, and part two provides guidelines for the hole diameters required. Table 1 below defines the dimensions for these metric torx pan thread rolling screws. Table 2 defines the recommended hole diameters for fitting of these thread rolling screws, in both steel and aluminium.

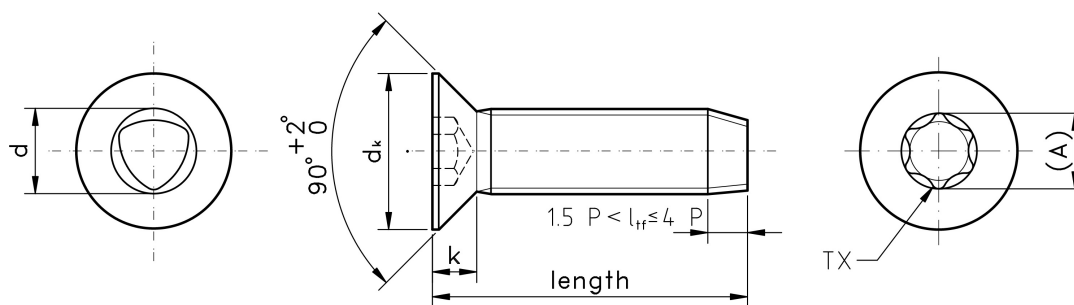

Figure 1: Torx Countersunk Thread Rolling Screw

### Notes to figure 1:

- a - This type of thread forming screw is known as a thread rolling screw and has a torx countersunk head, requiring a torx key to fit the fastener. Torx countersunk screws are also known as a star, T-multidrive, 6 lobe and hexalobular, and these screws are a type of tapping screw. The Torx drive design allows for a higher torque to be exerted over other drives.
- b - The length of the tapering tip is at least 1.5 P (pitches or threads) and should not exceed 4 P.

## Application Notes

- Please see Table 2 for guideline values for the hole diameters, from DIN 7500-2. These hole diameters are the result of practical tests carried out by manufacturers and users. The values given are intended for guidance and they are assigned to various materials and lengths of engagement.
- To achieve optimum functional performance, thread forming screws need to be suitably lubricated.

**Table 1: Dimensions & Tolerances according to DIN 7500-1**

Thread, d		M2.5	M3	M3.5	M4	M5	M6	M8
head diameter, dk	Max.	4.7	5.5	7.3	8.4	9.3	11.3	15.8
head height, k	Max.	1.5	1.65	2.35	2.7	2.7	3.3	4.65
recess depth, t	Min.	0.66	0.7	1.16	1.14	1.12	1.39	2.28
	Max.	0.79	0.83	1.32	1.53	1.51	1.78	3.2
drive, T		T8	T10	T15	T20	T25	T30	T40

**Table 2: Guidline Values for Hole Diameters according to DIN 7500-2**

Thread Size, d	M2.5		M3		M3.5		M4		M5		M6		M8		M10	
Length of Engagement	Hole Diameter d <sub>h</sub>															
	St	Al	St	Al	St	Al	St	Al	St	Al	St	Al	St	Al	St	Al
2	2.25	-	-	-	-	-	-	-	-	-	-	-	-	-	-	-
2.5	2.25	-	2.75	-	-	-	-	-	-	-	-	-	-	-	-	-
3	2.30	-	2.75	-	3.20	-	-	-	-	-	-	-	-	-	-	-
3.5	2.30	-	2.75	-	3.20	-	3.65	-	-	-	-	-	-	-	-	-
4	2.30	-	2.75	-	3.20	-	3.65	-	4.60	-	-	-	-	-	-	-
5	2.30	-	2.75	-	3.20	-	3.70	-	4.60	-	5.50	-	-	-	-	-
6	-	2.30	2.75	3.20	-	3.70	-	4.60	-	5.50	-	-	-	-	-	-
6.5	-	2.30	-	2.75	3.20	-	3.70	-	4.60	-	5.50	-	7.45	-	-	-
7	-	2.30	-	2.75	3.20	3.70	-	4.65	-	5.55	-	7.45	-	-	-	-
7.5	-	2.30	-	2.75	-	3.20	3.70	-	4.65	-	5.55	-	7.45	-	-	-
8	-	-	-	2.75	-	3.20	3.70	4.65	-	5.55	-	7.45	-	9.35	-	-
9	-	-	-	2.75	-	3.20	-	3.70	4.65	-	5.55	-	7.45	-	9.35	-
10	-	-	-	-	-	-	-	3.70	4.65	5.55	-	7.45	-	9.35	-	-
10.5	-	-	-	-	-	-	-	-	4.65	5.55	-	7.45	-	9.35	-	-
12	-	-	-	-	-	-	-	-	4.65	5.60	7.45	-	9.35	-	-	-
>12 to ≤15	-	-	-	-	-	-	-	-	-	-	5.60	7.45	-	9.35	-	-
>15 to ≤16	-	-	-	-	-	-	-	-	-	-	5.60	7.50	9.35	-	-	-
>16 to ≤18	-	-	-	-	-	-	-	-	-	-	5.60	-	7.50	9.35	-	-
>18 to ≤20	-	-	-	-	-	-	-	-	-	-	-	-	7.50	9.35	-	-
>20 to ≤24	-	-	-	-	-	-	-	-	-	-	-	-	7.50	-	9.35	-
>24 to ≤30	-	-	-	-	-	-	-	-	-	-	-	-	-	-	9.40	-

For further details, please refer to the ISO/DIN standard document for this item.