

[Browse Product Range >](#)

Westfield Fasteners Product Specification:

Rivet Nuts - Reduced Countersunk Head, Part Hexagonal Shank, Closed Type

This product guide contains the specification for blind rivet nuts with a reduced or small countersunk head, part hexagonal shank and a closed end. These are a stock item available from Westfield Fasteners.

Product Description

Reduced countersunk head rivet nuts are a specialist version of a full countersunk head rivet nut. These reduced countersunk heads are less common, but provide an almost flush finish where a non-interference fit is not critical. They are able to be installed without the need to produce a countersunk pilot hole and are therefore more cost effective. The small countersunk height is ideal for use with very thin gauge sheet materials and clamping thin single sheet material. The part hexagonal body has a slight reduction in torque loading in comparison to the full hexagonal body. The closed end allows for these rivet nuts to be used where an air tight or water tight seal is required.

Blind rivet nuts are used for attachments into sheet metals and thin metal gauge parts, such as panels, tubes and castings. The riveted nut will then allow you to attach and detach components easily using the correct sized bolt. The larger sized rivet nuts can clamp together multiple layers of sheet materials. Blind rivet nuts are also known as riv nuts, blind nuts and nutserts.

Install by inserting the rivet nut into a correctly sized hexagonal hole within the sheet material. Compress the rivet nut using a pneumatic powered or hand rivet nut tool, which grips it firmly to the sheet material. In the compression process, the thinner walled section without the thread collapses to form a collar on the blind side of the sheet material. This prevents the nut from being pulled back through the hole and fixes it securely to the sheet material.

Like blind rivets, blind rivet nuts do not require access to the back of the material. The strength of the riveted joint will vary for each application, as factors such as the material strengths, the diameter of the rivet nut, and the spacing between the rivet nuts will all effect the final shear and tensile strengths.

Product Information

See the dimensions in the tables below for sizes from M4 to M12, along with information on grip range, pre-drilled hole sizes, tensile strength and tightening torque. The tightening torque specifications are guide values depending on the material of the original component and must be checked by testing the component.

The grip range is the total thickness of the materials to be joined.

This type of rivet nut is available in A2 and A4 Stainless Steel. A2 will provides good corrosion and oxidation resistance for both indoor and outdoors. A4 is marine grade stainless steel, which offers better corrosion and oxidation resistance and is best for wet and salty environments.

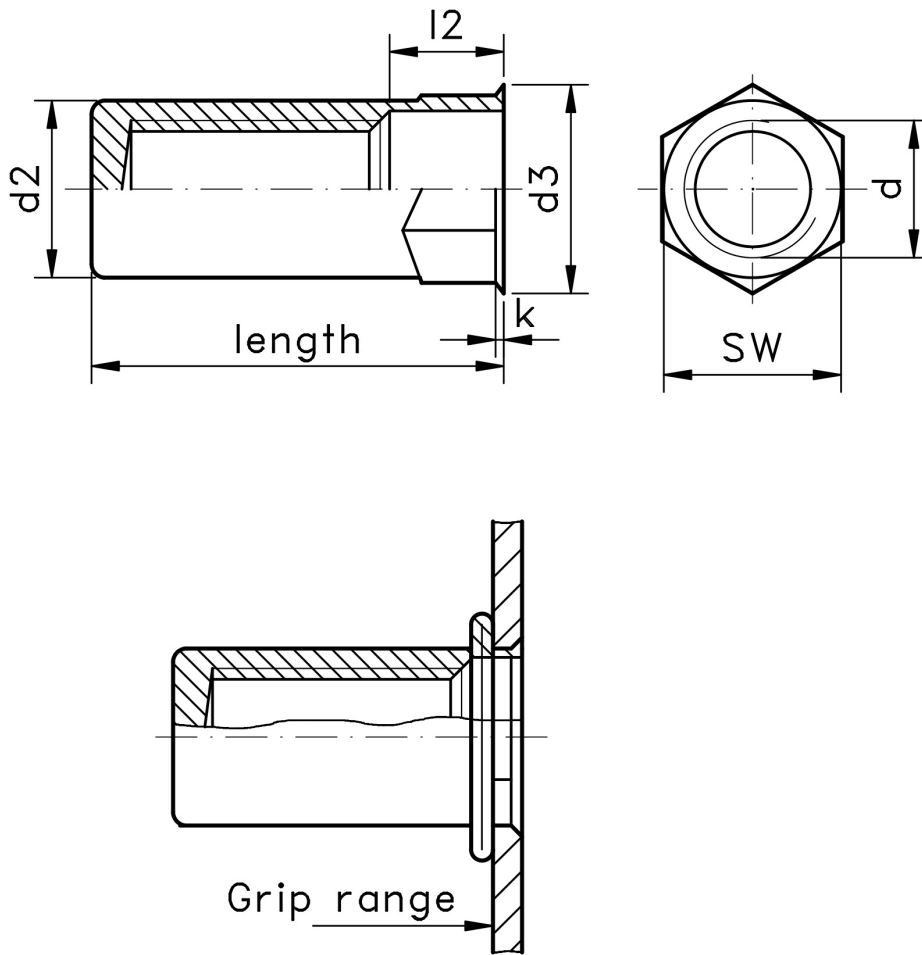

Figure 1: Blind rivet nut with a reduced countersunk head, part hexagonal body and closed end

Table 1: Dimensions & Tolerances (mm) for Stainless Steel Variants

Thread (d)	Grip Range	Hole Size	Body Diameter (d2)	Flange Diameter (d3)	Flange Thickness (k)	Overall Body Length (l)	Length 2 (l2)	Shear Force (N)	Tensile Strength (N)
M3	0.3 - 2.5	5	4.9	6	0.5	15.5	4.2	900	3900
M4	0.5 - 3.0	6	5.9	7	0.6	16.5	4.5	1500	6800
M5	0.5 - 3.0	7	6.9	8		19	5.2	2000	11500
M6	0.5 - 3.0	9	8.9	10		22	6.3	3000	16500
M8	0.5 - 3.0	11	10.9	12		25	6.8	4400	25000
M10	0.8 - 3.5	13	12.9	14		30	9	5000	32000
M12	0.8 - 4.0	16	15.9	17.5		31.1	9.3	6500	34000

Table 2: Dimensions & Tolerances (mm) for Bright Zinc Plated Variants

Thread (d)	Grip Range	Hole Size	Body Diameter (d2)	Flange Diameter (d3)	Flange Thickness (k)	Body Overall Length	Max Tightening Torque (Nm)	Tensile Strength (N)
M4	0.5 - 2.0	6.0	5.9	7.0	0.5	15.5	4.0	6800
	2.0 - 4.0					18.0		
M5	0.5 - 2.5	7.0	6.9	8.0		18.0	6.5	10000
	2.5 - 4.5					23.0		
M6	1.0 - 3.5	9.0	8.9	10.0	0.6	21.5	12.0	15000
	3.0 - 5.0					23.5		
M8	1.0 - 3.5	11.0	10.9	12.0	0.7	24.0	31.0	27000
	3.5 - 5.5					25.0		
M10	1.0 - 4.0	13.0	12.9	14.5	0.8	30.5	42.0	28500
	4.0 - 6.0					35.0		

E&OE