



 westfieldfasteners.co.uk
 +44 (0)1844 201133
 enquiries@westfieldfasteners.co.uk

Westfield Fasteners Product Specification:

DIN 936 - Hex Thin Nuts (Standard Pitch)

This product guide contains the specification for a type of metric threaded hexagon thin nut, specifically manufactured to the DIN standard DIN 936. This item is a standard part available from Westfield Fasteners.

Product Description

Hex thin nuts manufactured to DIN 936 are a low type hex nut. Their height is between that of a standard full nut (DIN 934) and the more popular and well known DIN 439 half nut. These nuts are also known as thin nuts or jam nuts and are often used in conjunction with other nuts in a locking arrangement. The slim flat profile of these hex nuts makes them useful where space is limited or where there is only a few threads of a bolt to engage with.

Scope of the DIN Standard

DIN 936 specifies the tolerances and variation of a form of metric threaded thin hexagon nut, for sizes from M8 up to and including M52. Fine pitch variants are also covered under this standard.

Table 1 below defines the overall dimensions and tolerances for these hex thin nuts manufactured to DIN 936.

The last edition of DIN 936 recommends manufacturers move to DIN 439 for nuts of this type. DIN 439 has itself been superseded since by ISO 4035. Despite this, off the shelf parts are currently more generally available in the older two specifications.

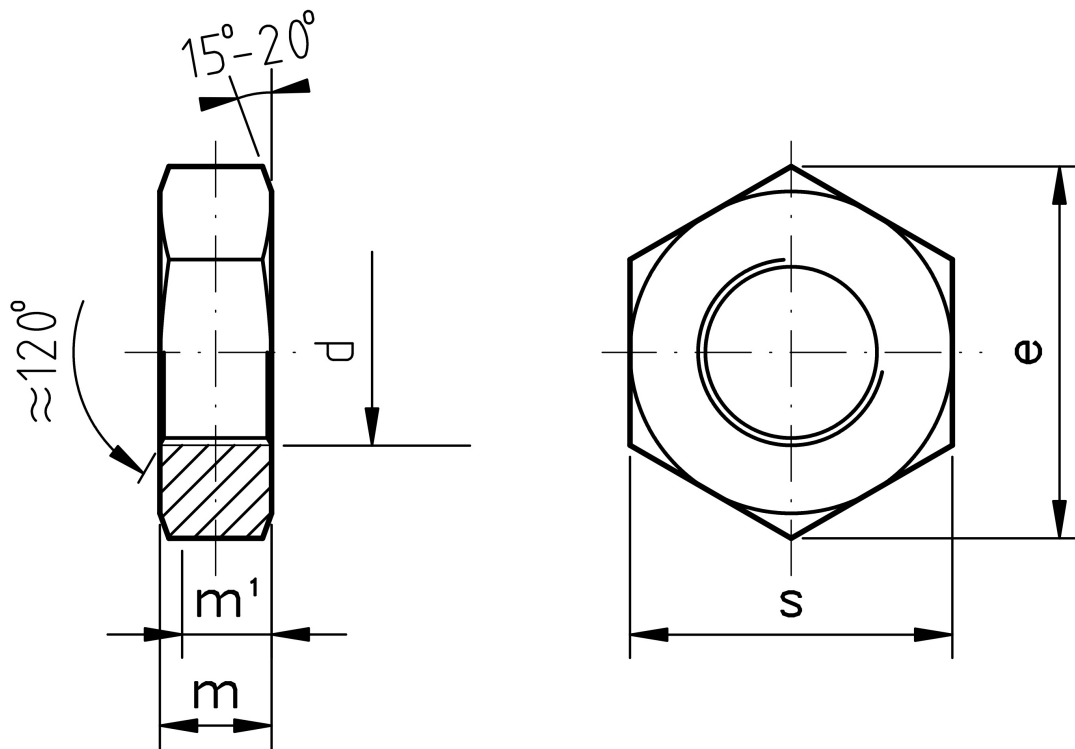

Figure 1: Hex Thin Nuts to DIN 936

Variations from DIN 936

DIN 936 covers materials including carbon steel, and A2 stainless steel. The hex nuts we stock in other materials and grades are made with reference to this standard, but are not mentioned specifically.

Table 1: Dimensions & Tolerances according to DIN 936 (mm)

Thread Size		M8	M10	M12	M14	M16	M18	M20	M22	M24	M27	M30	M33	M36	M39	M42	M45	M48	M52
		M8x1	M10x1	M12x1.25	M14x1.5	M16x1.5	M18x1.5	M20x1.5	M22x1.5	M24x1.5	M27x1.5	M30x1.5	M33x1.5	M36x1.5	M39x1.5	M42x1.5	M45x1.5	M48x1.5	M52x1.5
		-	M10x1.25	M12x1.5	-	-	M18x2	M20x2	M22x2	M24x2	M27x2	M30x2	M33x2	M36x2	M39x2	M42x2	M45x2	M48x2	M52x2
		-	-	-	-	-	-	-	-	-	-	-	-	M36x3	M39x3	M42x3	M45x3	M48x3	M52x3
p		1.25	1.5	1.75	2	2	2.5	2.5	2.5	3	3	3.5	3.5	4	4	4.5	4.5	5	5
d ₂	min	8	10	12	14	16	18	20	22	24	27	30	33	36	39	42	45	48	52
	max	8.75	10.8	13	15.1	17.3	19.5	21.6	23.7	25.9	29.1	32.4	35.6	38.9	42.1	45.4	48.6	51.8	56.2
d _w	min	11.3	15.3	17.2	20.2	22.2	25.3	28.2	29.5	33.2	38	42.7	46.6	51.1	55.9	60.6	64.7	69.4	74.2
e	min	15.38	18.90	21.1	24.49	26.75	29.56	32.95	35.03	39.55	45.20	50.85	55.37	60.79	66.44	71.30	78.95	82.60	88.25
m	max=nom	5	6	7	8	8	9	9	10	10	12	12	14	14	16	16	18	18	20
	min	4.7	5.7	6.64	7.42	7.42	8.42	8.1	9.1	9.1	10.9	10.9	12.9	12.9	14.9	14.9	16.9	16.9	18.7
m ¹	min	3.8	4.6	5.3	5.9	5.9	6.7	6.5	7.3	7.3	8.7	8.7	10.3	10.3	11.9	11.9	13.5	13.5	15.0
s	max=nom	13	17	19	22	24	27	30	32	36	41	46	50	55	60	65	70	75	80
	min	12.73	16.73	18.67	21.67	23.67	26.16	29.16	31	35	40	45	49	53.8	58.8	63.1	68.1	73.1	78.1
Mass (7.85 kg/dm ³), in kg per 1000 units =		4	8.6	12.1	18.2	20.1	29.6	36.3	43.8	58	90	110	155	190	260	307	400	460	580

For further details, please refer to the DIN standard document for this item.