



[Browse Product Range >](#)

Westfield Fasteners Product Specification:

DIN 7337 - Blind rivets with Countersunk Head

This product guide contains the specification for blind rivets or pop rivets with a countersunk head as available from Westfield Fasteners. The basis of this specification is the DIN standard DIN 7337.

Product Description

Blind rivets, also known as pop rivets, are an unthreaded fastener. Blind rivets are available in many variations, with differing head types, material combinations and colours. This specification focusses on countersunk head types to the DIN standard DIN 7337. Blind rivets create a permanent fixing and can be used when access is only available on one side of the workpiece or joint. The rivet is fixed in place with a rivet gun.

Scope of the DIN standard.

DIN 7337 specifies the dimensions, design, strength and finish of break mandrel blind rivets. Each rivet consists of a rivet body and an integral mandrel, which breaks off during application. This standard covers all the typical head types and material combinations.

The data in the tables below are provided to assist with installation of these blind rivets. Table 1 defines the overall dimensions and tolerances of this fastener type. Tables 2 and 3 offer minimum shear and tensile strengths respectively by material. Table 4 offers a nominal size for the holes to be used with these rivets. Tables 5, 6, 7 and 8 give grip length ranges for the various size and material combinations available.

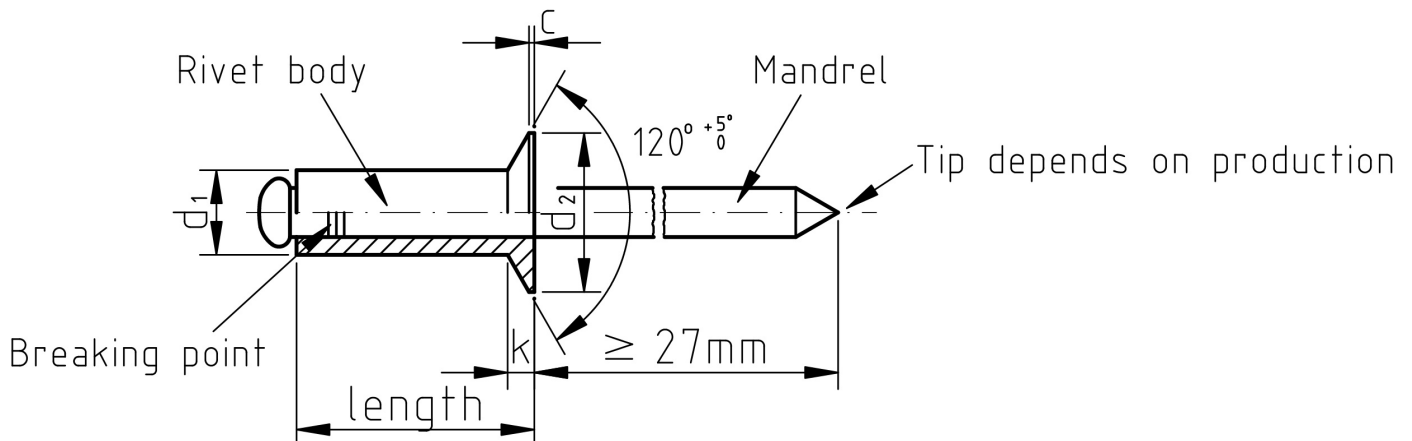

Figure 1: Blind rivets with countersunk head

User Information:

- The tolerance on the lengths of the rivets can vary from being 1mm longer to 0.2mm shorter.

Table 1: Dimensions & Tolerances according to DIN 7337

d_1	Nominal Size	Metric	-	3	-	4	-	5	6	-	
		Imperial	2.4	-	3.2	-	4.8	-	-	6.4	
	Limit Deviations	+0.08 / -0.1				+0.08 / -0.15					
d_2	Nominal Size	-	6		7.5	p		11	12		
	Limit Deviations	-	0 / -0.4		0 / -0.5		0 / -0.7				
c	max	-	0.3			0.4					
k	=	-	0.9		1	1.2		1.5	1.6		
r	max	0.2			0.3		0.4	0.5			

Table 2: Shear Strength according to DIN 7337

Material of rivet body	Diameter d_1							
	2.4	3	3.2	4	4.8	5	6	6.4
	Minimum shear force, in N							
Aluminium	300	500	600	800	1400	1600	2500	2800
Steel	-	800	1000	1500	2400	2600	3300	3600
A2 Stainless	-	1600	1800	2500	3800	4200	-	-
Nickel Alloy	-	-	1400	2000	3300	-	-	-
Copper Alloy	-	800	1000	1500	2300	-	-	-
Copper	-	600	700	1000	-	-	-	-

Table 3: Tensile Strength according to DIN 7337

Material of rivet body	Diameter d_1							
	2.4	3	3.2	4	4.8	5	6	6.4
	Minimum tensile force, in N							
Aluminium	300	400	500	800	1200	1300	2000	2100
Steel	-	900	1100	2000	3000	3200	3800	4000
A2 Stainless	-	2000	2300	3500	4500	5000	-	-
Nickel Alloy	-	-	2000	2800	3500	-	-	-
Copper Alloy	-	900	1100	2000	3000	-	-	-
Copper	-	700	800	1500	-	-	-	-

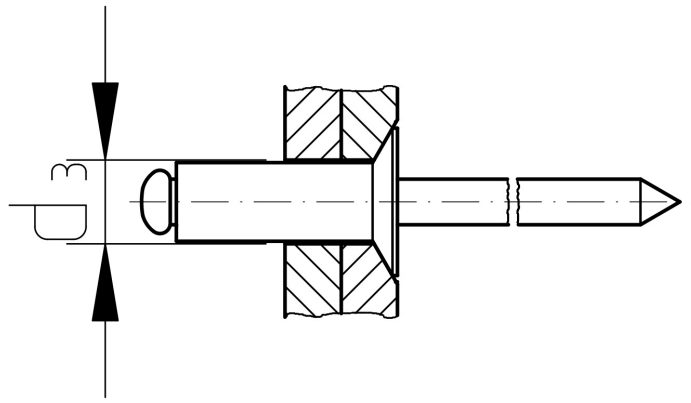

Table 4/Figure 2: Joint hole diameter according to DIN 7337

d_1		2.4	3	3.2	4	4.8	5	6	6.4
d_3	nom	2.5	3.1	3.3	4.1	4.9	5.1	6.1	6.5
	limit deviations	+0.05 / 0	+0.1 / 0				+0.2 / 0		

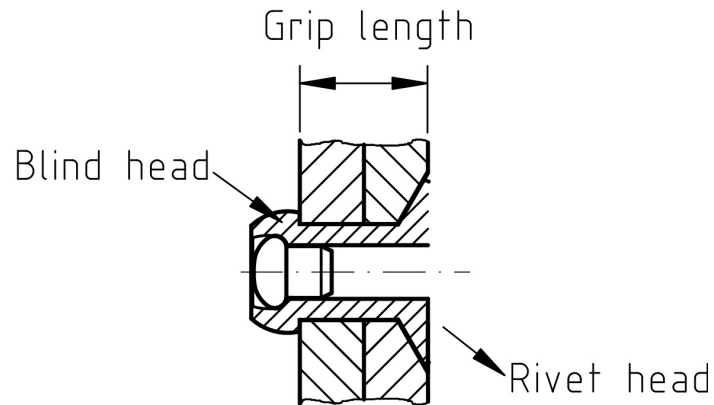

Figure 3: Grip length

Table 5: Rivets with body made of Al alloy and material made of steel or A2 stainless according to DIN 7337

d_1	2.4	3	3.2	4	4.8	5	6	6.4
length	Grip length range							
4	0.5 to 2	0.5 to 1.5	-	-	-	-	-	-
6	2 to 4	1.5 to 3.5	1.5 to 3	2 to 3	-	-	-	-
8	4 to 6	3.5 to 5.5	3 to 5	3 to 4.5	2 to 4	-	-	-
10	-	5.5 to 7	5 to 6.5	4.5 to 6	4 to 6	-	-	-
12	-	7 to 9	6.5 to 8.5	6 to 8	6 to 8	2 to 6	-	-
16	-	9 to 13	8.5 to 12.5	8 to 12	8 to 11	6 to 10	-	-
20	-	13 to 17	12.5 to 16.5	12 to 16	11 to 15	10 to 14	-	-
25	-	17 no 22	16.5 to 21.5	16 to 21	15 to 20	14 to 18	-	-
30	-	-	-	21 to 25	20 to 24	18 to 23	-	-
35	-	-	-	25 to 30	24 to 29	-	-	-
40	-	-	-	30 to 35	29 to 34	-	-	-
45	-	-	-	35 to 40	34 to 39	-	-	-
50	-	-	-	40 to 45	39 to 44	-	-	-

Table 6: Rivet bodies made of steel and mandrel made of steel according to DIN 7337

d₁	2.4	3	3.2	4	4.8	5	6	6.4
length	Grip length range							
6	-	0.5 to 3	0.5 to 2.5	-	-	-	-	-
8	-	3 to 5	2.5 to 4.5	2 to 4	-	-	-	1 to 3
10	-	5 to 7	4.5 to 6.5	4 to 6	2.5 to 4.5	-	-	-
12	-	7 to 9	6.5 to 8.5	6 to 8	4.5 to 6.5	-	-	3 to 6
16	-	9 to 12.5	8.5 to 12	8 to 11	6.5 to 10.5	-	-	6 to 9
20	-	12.5 to 16.5	12 to 16	11 to 15	10.5 to 14.5	-	-	9 to 13
25	-	-	16 to 21	15 to 20	14.5 to 19.5	-	-	13 to 17
30	-	-	-	20 to 25	-	-	-	-
35	-	-	-	25 to 30	-	-	-	-

Table 7: Rivet bodies made of A2 stainless, nickel alloy and copper alloy and mandrel of steel or A2 stainless according to DIN 7337

d₁	2.4	3	3.2	4	4.8	5	6	6.4
length	Grip length range							
6	-	1 to 3	1 to 2.5	1 to 2	-	-	-	-
8	-	3 to 5	2.5 to 4.5	2 to 4	-	-	-	-
10	-	5 to 7	4.5 to 6.5	4 to 6	-	-	-	-
12	-	7 to 9	6.5 to 8.5	6 to 8	-	-	-	-
16	-	-	8.5 to 12	8 to 11	-	-	-	-
20	-	-	12 to 16	11 to 15	-	-	-	-
25	-	-	16 to 21	15 to 20	-	-	-	-

Table 8: Rivet bodies made of copper and mandrel made of steel, A2 stainless or bronze wire according to DIN 7337

d₁	2.4	3	3.2	4	4.8	5	6	6.4
length	Grip length range							
4	-	0.5 to 1.5	-	-	-	-	-	-
6	-	1.5 to 3	2.5 to 3.5	-	-	-	-	-
8	-	3 to 5	3.5 to 4.5	-	-	-	-	-
10	-	5 to 7	4.5 to 6.5	-	-	-	-	-
12	-	7 to 9	6.5 to 8.5	-	-	-	-	-

For further details, please refer to the ISO/DIN standard document for this item.