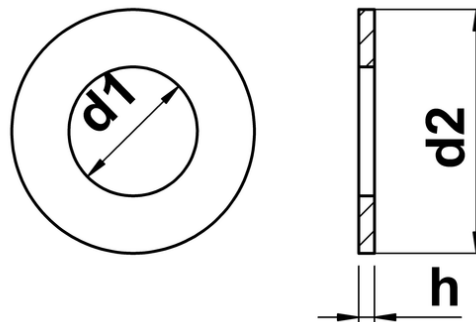



Table 3 Flat Washers

Flat washer manufactured to BS 3410 Table 3 Light Specification.



no.	d1 max (+)	d1 max (-)	d2 max (+)	d2 min (-)	h
1/4	0.270	0.270	0.560	0.560	0.036
5/16	0.330	0.330	0.630	0.620	0.040
3/8	0.400	0.390	0.750	0.750	0.048
7/16	0.460	0.450	0.880	0.870	0.048
1/2	0.520	0.520	1.000	1.000	0.056
9/16	0.590	0.590	1.130	1.120	0.056
5/8	0.660	0.650	1.250	1.240	0.072
3/4	0.780	0.780	1.500	1.490	0.072
7/8	0.910	0.900	1.630	1.620	0.072
1	1.030	1.030	1.880	1.870	0.072
1-1/8	1.160	1.150	2.130	2.120	0.092
1-1/4	1.280	1.280	2.380	2.360	0.116