

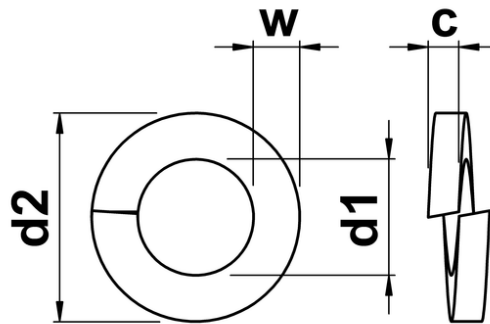

## Rectangular Section Spring Washers

Spring washer designed to help prevent loosening of bolted joints under vibration. This type has a rectangular section and is manufactured to ASME B18.21.1-1999.



A	d1 max.	d1 min.	d2	c	w
No.2	0.094	0.088	0.172	0.020	0.035
No.3	0.107	0.101	0.195	0.025	0.040
No.4	0.120	0.114	0.209	0.025	0.040
No.5	0.133	0.127	0.236	0.031	0.047
No.6	0.148	0.141	0.250	0.031	0.047
No.8	0.174	0.167	0.293	0.040	0.055
No.10	0.200	0.193	0.334	0.047	0.062
No.12	0.227	0.220	0.377	0.056	0.070
1/4	0.260	0.252	0.487	0.062	0.109
5/16	0.322	0.314	0.583	0.078	0.125
3/8	0.385	0.377	0.680	0.094	0.141
7/16	0.450	0.440	0.776	0.109	0.156
1/2	0.512	0.502	0.869	0.125	0.171
9/16	0.574	0.564	0.965	0.141	0.188
5/8	0.641	0.628	1.073	0.156	0.203
11/16	0.704	0.691	1.170	0.172	0.219
3/4	0.766	0.753	1.265	0.188	0.234
13/16	0.832	0.816	1.363	0.203	0.250
7/8	0.894	0.878	1.459	0.219	0.266

<b>A</b>	<b>d1 max.</b>	<b>d1 min.</b>	<b>d2</b>	<b>c</b>	<b>w</b>
<b>15/16</b>	0.958	0.941	1.556	0.234	0.281
<b>1</b>	1.024	1.003	1.656	0.250	0.297