

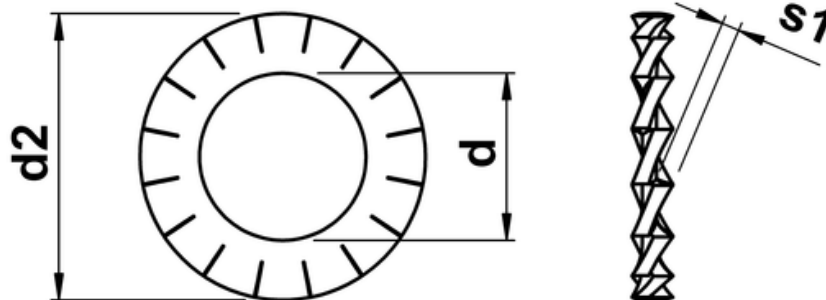

External Serrated Lock Washer

A toothed or perforated washer usually employed in electrical connections such as battery terminals, but can also be used in assemblies to help prevent loosening. This variant includes teeth on the external diameter and therefore accords with DIN 6798A.



d	for	d2	s1
2.2	M2	4.5	0.3
2.7	M2.5	5.5	0.4
3.2	M3	6.0	0.4
3.7	M3.5	7.0	0.5
4.3	M4	8.0	0.5
5.1	M5	9.0	0.5
5.3	M5	10.0	0.6
6.4	M6	11.0	0.7
7.4	M7	12.5	0.8
8.2	M8	14.0	0.8
8.4	M8	15.0	0.8
10.5	M10	18.0	0.9
13.0	M12	20.5	1.0
15.0	M14	24.0	1.0
17.0	M16	26.0	1.2
19.0	M18	30.0	1.4
21.0	M20	33.0	1.4
23.0	M22	36.0	1.5

d	for	d2	s1
25.0	M24	38.0	1.5
28.0	M27	44.0	1.6
31.0	M30	48.0	1.6