

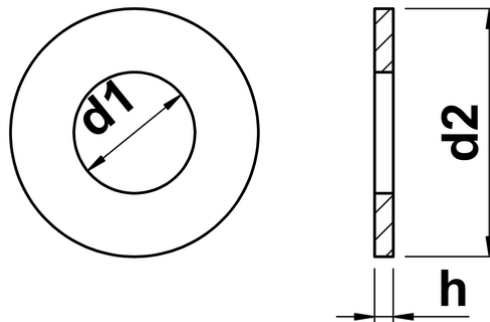

## SAE Flat Washers

Flat washer to American SAE specifications, now part of the Unified Thread Standard. Washers with a smaller external diameter than that of an equivalent USS washer. Conforms to ASME B18.21.1-1999.



no.	d1	d1 max	d1 min	d2	d2 max	d2 min	h	h max	h min
<b>6</b>	0.156	0.187	0.156	0.375	0.406	0.344	0.046	0.065	0.036
<b>8</b>	0.187	0.219	0.188	0.437	0.469	0.407	0.046	0.065	0.036
<b>3/16</b>	0.218	0.250	0.219	0.500	0.531	0.469	0.046	0.065	0.036
<b>12</b>	0.250	0.281	0.250	0.562	0.583	0.531	0.062	0.080	0.051
<b>1/4</b>	0.281	0.312	0.281	0.625	0.656	0.594	0.062	0.080	0.051
<b>5/16</b>	0.343	0.375	0.344	0.687	0.719	0.657	0.062	0.080	0.051
<b>3/8</b>	0.406	0.437	0.406	0.812	0.843	0.781	0.062	0.080	0.051
<b>7/16</b>	0.468	0.500	0.469	0.921	0.953	0.891	0.062	0.080	0.051
<b>1/2</b>	0.531	0.562	0.531	1.062	1.093	1.031	0.093	0.121	0.074
<b>9/16</b>	0.593	0.625	0.594	1.018	1.219	1.157	0.093	0.121	0.074
<b>5/8</b>	0.656	0.687	0.656	1.312	1.343	1.281	0.093	0.121	0.074
<b>3/4</b>	0.812	0.843	0.812	1.500	1.531	1.469	0.140	0.160	0.108
<b>7/8</b>	0.937	0.969	0.938	1.750	1.781	1.719	0.140	0.160	0.108
<b>1"</b>	1.062	1.094	1.062	2.000	2.031	1.969	0.140	0.160	0.108
<b>1-1/8</b>	1.018	1.251	1.188	2.250	2.313	2.187	0.140	0.160	0.108
<b>1-1/4</b>	1.312	1.375	1.312	2.500	2.563	2.437	0.156	0.192	0.136
<b>1-3/8</b>	1.437	1.501	1.438	2.750	2.813	2.687	0.156	0.213	0.136
<b>1-1/2</b>	1.056	1.625	1.562	3.000	3.063	2.937	0.156	0.213	0.153