

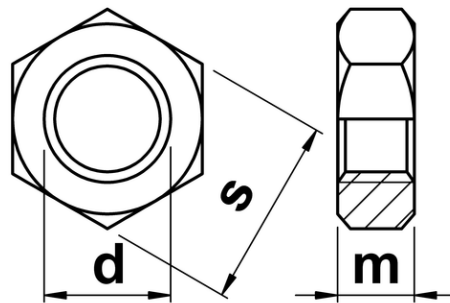

UNC Half Nuts (Lock Nut) ASME B18. 2.2

Nut conforming to ASME B18.2.2. Also known as a half nut, thin nut, or jam nut. Typically fitted with a spanner or ratchet with socket, often used in pairs in a nut locking arrangement. A popular nut type, and used for decades on all types of assembly throughout the world.



d	s	m
1/4	0.438	0.163
5/16	0.500	0.195
3/8	0.562	0.227
7/16	0.688	0.260
1/2	0.750	0.323
9/16	0.875	0.324
5/8	0.938	0.387
3/4	1.125	0.446
7/8	1.312	0.510
1	1.500	0.575
1 1/4	1.875	0.782
1 1/2	2.250	0.911