

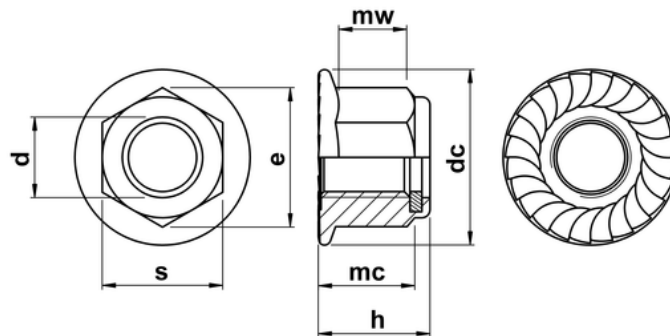

Hex Serrated Flange Nuts with Nylon Insert

A prevailing torque type hexagon nut incorporating a flange and nylon insert to help prevent loosening when fitted. This particular version has serrations on the base of the flange. A non-serrated version is also available. Manufactured to DIN 6926.



d	thread pitch	dc	e	h	mc	mw	s
(M3)	0.50	(8.00)	-	(4.74-5.10)	-	(1.7)	(5.32-5.50)
(M4)	0.70	(10.00)	-	(5.74-6.10)	-	(1.9)	(6.78-7.00)
M5	0.80	11.80	8.79	6.52-7.10	4.70	2.5	7.78-8.00
M6	1.00	14.20	11.05	8.52-9.10	5.70	3.1	9.78-10.00
M8	1.25	17.90	14.38	10.40-11.10	7.60	4.6	12.73-13.00
M10	1.50	21.80	16.64	12.80-13.50	9.60	5.6	14.73-15.00
M12	1.75	26.00	20.03	15.40-16.10	11.60	6.8	17.73-18.00